

32 oz. Pop-O-Gold with Base and RH Chute – 2011EBRCH

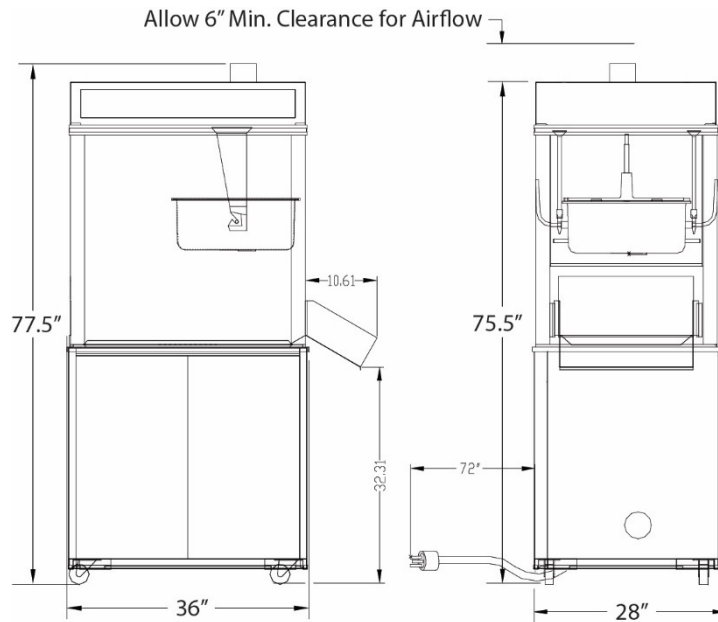

Electrical Specifications:

120/208 V~ or 120/240 V~, 5752 W, 60 Hz
(NEMA L14-30P & L14-30R)

Unit designed to operate on single phase, 30 amp, 4 wire supply (2 hot, 1 neutral, 1 ground). Wall receptacle supplied with unit.

Agency Approvals: ETL, cETL, ETLs, CE

Oil Delivery System: Units are equipped with either the 2114E Bucket Pump System or the 2257 Bag-in-a-Box System. Poppers with Salt/Sweet or Flexi-pop options, use either 2257D or 2114D, with 2 oil settings.

Lighting: LED illuminated red & white “popcorn” sign is standard. LED Neon sign with red “popcorn” and yellow “puffs” is an option. All domes are reversible for front or back counter.

Features: Base included with unit, (RCH) Right hand chute included.

Options: D (Deep well corn storage), N (LED Neon “Popcorn” sign), Z (Flexi-Pop 32oz. or 18oz. with a “flip of a switch”), S (Salt-Sweet Switch), V (External vent hood delay circuit (Popper has a timed control circuit to permit an external exhaust hood to run for up to 20 minutes after the kettle is turned off)).

Gold Medal Products Co.
10700 Medallion Drive Cincinnati, Ohio 45241-4807
Phone: 513-769-7676 fax: 513-769-8500
E-mail: www.gmpopcorn.com